

Series  
CAM

# Compressed Air Meter

Steady-State and Cumulative Totals PNP/4-20 mA Output

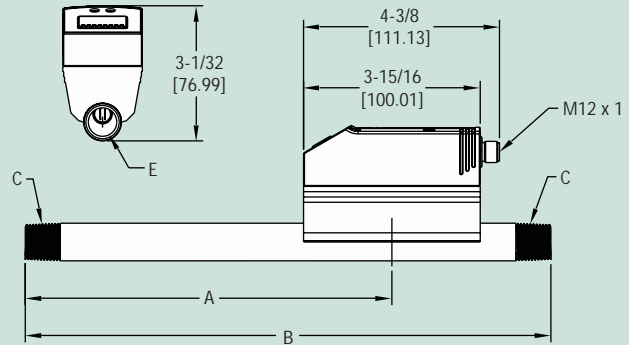

## DIMENSIONS

MODEL NO	A	B	C	D	E
CAM-10	10-53/64	18-45/64	2 NPT	5-1/4	Ø2-1/64
	[275.3]	[475.06]		[133.35]	[Ø51.2]
CAM-20	8-9/32	11-13/16	1/2 NPT	3-1/32	Ø41/64
	[210.34]	[300.04]		[76.99]	[Ø16.27]
CAM-30	14-49/64	18-45/64	1 NPT	3-31/64	Ø1-5/64
	[375.05]	[475.06]		[88.5]	[Ø27.38]

The Series CAM Compressed Air Meter operates by the calorimetric measuring principle to detect the standard volume flow of operating compressed air. It is designed specifically to evaluate the current flow rate and the current consumed quantity in compressed air systems. With an easily programmable digital display, this unit offers a quick, accurate readout. The Series CAM is constructed of high-grade materials and is virtually maintenance free.

**Model CAM-10**, 2" NPT, 1.4 - 412.0 SCFM

**Model CAM-20**, 1/2" NPT, 0.2 - 44.1 SCFM

**Model CAM-30**, 1" NPT, 1.0 - 132.4 SCFM

## ACCESSORIES

**A-283**, 4-Wire Connector

Class	Max. Oil Content	Max. Residual Dust		Max. Residual Water	
	Oil Content mg/m <sup>3</sup>	Dust Concentration mg/m <sup>3</sup>	Particle Size mg/µm	Residual Water g/m <sup>3</sup>	Pressure Dew Point °C
1	0.01	0.1	0.1	0.003	-70
2	0.1	1	1	0.117	-40
3	1	5	5	0.880	-20
4	5	8	15	5.953	+3
5	25	10	40	7.732	+7
6	-	-	-	9.356	+10

## SPECIFICATIONS

**Service:** Compressed air; Air quality (see chart).

**Wetted Materials:** Stainless Steel (304S15), ceramics, glass passivated, PEEK, polyester, Fluoroelastomer, anodized aluminum.

**Response Time:** < 0.1 seconds.

**Temperature Limit:** 32 to 140°F (0 to 60°C).

**Pressure Limit:** 232 psig (16 bar).

**Humidity Limit:** 90% RH.

**Power Requirements:** 19-30 DC.

**Output Signal:**

Output 1: PNP Open Collector: VOUT(max)=30 VDC / ISINK(max)= 250mA

Output 2: 4-20mA (scaleable) or PNP Open Collector.

**Loop Resistance:** 500 ohms.

**Current Consumption:** <100 mA.

**Electrical Connections:** 4 pin M12(Micro) Cable Connection.

**Process Connections:** 1/2", 1" and 2" NPT.

**Display:** 4-digit alpha numeric red LED.

**Enclosure Rating:** IP 65 (NEMA 4X).

**Mounting Orientation:** Vertical, Horizontal, Side with pipe length facing left.

**Weight:** CAM-10: 12.5 lb;

CAM-20: 2.35 lb;

CAM-30: 4.16 lb.

**Agency Approvals:** CE.