

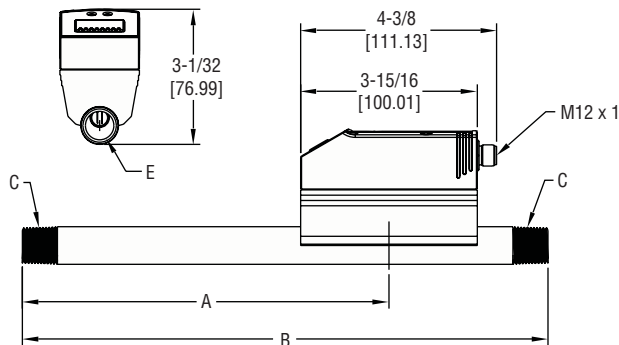

Series CAM Compressed Air Meter

Specifications - Installation and Operating Instructions



DIMENSIONS

MODEL NO	A	B	C	D	E
CAM-10	10-53/64	18-45/64	2 NPT	5-1/4	Ø2-1/64
	[275.3]	[475.06]		[133.35]	[Ø51.2]
CAM-20	8-9/32	11-13/16	1/2 NPT	3-1/32	Ø41/64
	[210.34]	[300.04]		[76.99]	[Ø16.27]
CAM-30	14-49/64	18-45/64	1 NPT	3-31/64	Ø1-5/64
	[375.05]	[475.06]		[88.5]	[Ø27.38]

The Series CAM Compressed Air Meter operates by the calorimetric measuring principle to detect the standard volume flow of operating compressed air. It is designed specifically to evaluate the current flow rate and the current consumed quantity in compressed air systems. With an easily programmable digital display, this unit offers a quick, accurate readout. The Series CAM is constructed of high-grade materials and is virtually maintenance free.

Read the product description before installing the unit, to ensure that the product is suitable for your application without any restrictions. Suitably qualified personnel must perform work on compressed air equipment. Ensure that the installation is at a standstill, before mounting components into or removing them from compressed air equipment. Ensure that neither people nor objects are endangered by moving parts before commissioning / restart of the installation. Non-adherence to the operating instructions or technical data can lead to personal injury and/or damage to property. In all applications, check compliance of the product materials with the media to be measured.

Class	Max. Oil Content	Max. Residual Dust		Max. Residual Water	
	Oil Content mg/m ³	Dust Concentration mg/m ³	Particle Size mg/µm	Residual Water g/m ³	Pressure Dew Point °C
1	0.01	0.1	0.1	0.003	-70
2	0.1	1	1	0.117	-40
3	1	5	5	0.880	-20
4	5	8	15	5.953	+3
5	25	10	40	7.732	+7
6	-	-	-	9.356	+10

Chart 1

SPECIFICATIONS

- Service:** Compressed air; Air quality (see chart 1).
- Wetted Materials:** Stainless Steel (304S15), ceramics, glass passivated, PEEK, polyester, Fluoroelastomer, anodized aluminum.
- Response Time:** < 0.1 seconds.
- Temperature Limit:** 32 to 140°F (0 to 60°C).
- Accuracy*:** 1.41 ±3% +0.3% FV; 3.44 ±6% MV +0.6% FV.
- Pressure Limit:** 232 psig (16 bar).
- Humidity Limit:** 90% RH.
- Power Requirements:** 19-30 DC.
- Output Signal:**
 - Output 1: PNP Open Collector: VOUT(max)=30 VDC / ISINK(max)= 250mA
 - Output 2: 4-20mA (scalable) or PNP Open Collector.
- Loop Resistance:** 500 ohms.
- Current Consumption:** <100 mA.
- Electrical Connections:** 4 pin M12(Micro) Cable Connection.
- Process Connections:** 1/2", 1" and 2" NPT.
- Display:** 4-digit alphanumeric red LED
- Enclosure Rating:** IP 65 (NEMA 4X).
- Mounting Orientation:** Vertical, Horizontal, Side with pipe length facing left.
- Ranges:**
 - CAM-10: 1.4-412.0 SCFM.
 - CAM-20: 0.2-44.1 SCFM.
 - CAM-30: 1.0-132.4 SCFM.
- Weight:** CAM-10: 12.5 lbs; CAM-20: 2.35 lbs; CAM-30: 4.16 lbs.
- Agency Approvals:** CE.

*Ref. Chart 1 for DIN ISO 8573 Standards
 e.g. 1.4.1. implies
 1 = 0.01mg/m³ oil content
 4 = 15 µm particle size and 8 mg/m³ particle density
 1 = -70°C dew pt., 3 mg/m³ residual water

ELECTRICAL CONNECTION

A suitably qualified electrician must connect the unit. Voltage supplied according to EN50178, SELV, PELV. The device shall be supplied from an isolating source and protected by an over-current device such that the limited voltage circuit requirements in accordance with UL 508 are met. Disconnect power before connecting the unit as follows in Figure 2.

Disconnect power before connecting the unit as follows:

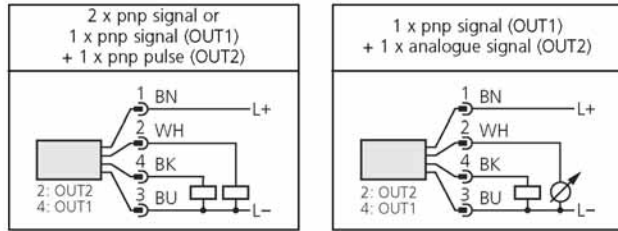

Core socket colors
1 = BN, 2 = WH (white), 3 = BU (blue), 4 = BK (black).

Figure 1

INSTALLATION

Location:

Select an area where the process temperature will remain between 32 and 140°F (0 to 60°C). Preferred mounting location is downstream from the cold dryer, near the load. If compressed air is fed into the main pipe through parallel pipes, the unit should be mounted in the main pipe.

Position: The unit may be positioned vertically, horizontally, and on its side with the pipe length left. Avoid positioning the unit on its side with the pipe length to the right. This may jeopardize the accuracy:

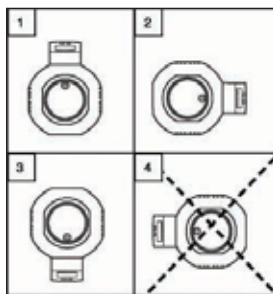

Figure 2

Mounting: To achieve the specified measurement accuracy, the following mounting conditions must be adhered to: defined inflow/outflow pipe lengths, defined flow cross-sectional area, fixed installation depth and correct positioning of the measuring elements. Integrate the pipe length so that the direction of flow and the marking arrow show in the same direction. In case of disturbances at the inflow side additional baffled pipes are recommended:

	90° elbow	B = 15 x pipe diameter (D)
	two 90° elbows, one plane	B = 20 x pipe diameter (D)
	two 90° elbows, two planes	B = 25 x pipe diameter (D)
	valve, slide	B = 45 x pipe diameter (D)

Figure 3

MAINTENANCE

After mounting, wiring and programming check whether unit operates correctly. Unit is maintenance free for media which will not adhere to measuring probes. Occasionally, probes should be visually checked for build-up. If necessary, clean probes with a suitable liquid (e.g. alcoholic solution). Avoid mechanical damage to measuring probes.

Display Key Functions:

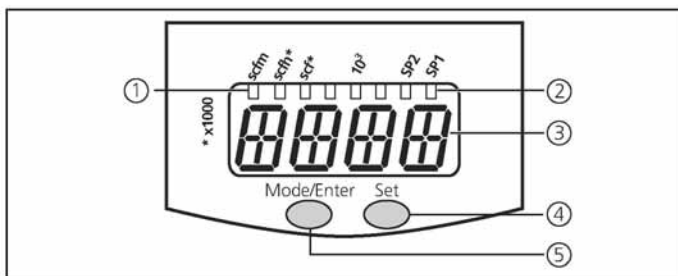

①	3 x LED green	Lighting LED = set display unit: - LEDs 1 / 2 = flow rate indication (standard volume flow). - LED 3 = quantity meter (current consumed quantity) LED 3 (flashing): consumed quantity before last reset.
②	3 x LED yellow	Display functions - 10 ³ : The displayed value must be multiplied with the factor 1000. - SP1 / SP2: Indication of the switching status, LED lights if the corresponding output is switched.
③	4-digit alphanumeric display	- Indication of the current standard volume flow. - Indication of the current consumed quantity. - Indication of the parameters and parameter values.
④	Set pushbutton	- Setting of the parameter values (scrolling by holding pressed; incremental by pressing briefly). - Change of the display unit in the Run mode.
⑤	Mode / Enter pushbutton	Selection of the parameters and acknowledgement of the parameter values.

scf = standard cubic feet
scfm = *** per minute
scfh = *** per hour

Chart 2

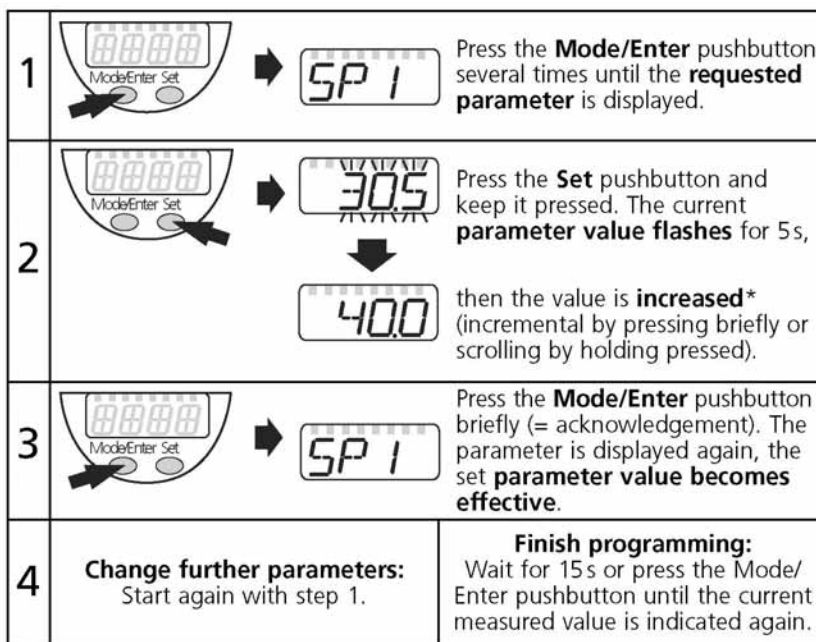

*To decrease the value, cycle past the maximum value, and the setting will restart from the minimum.

Figure 4

Menu structure

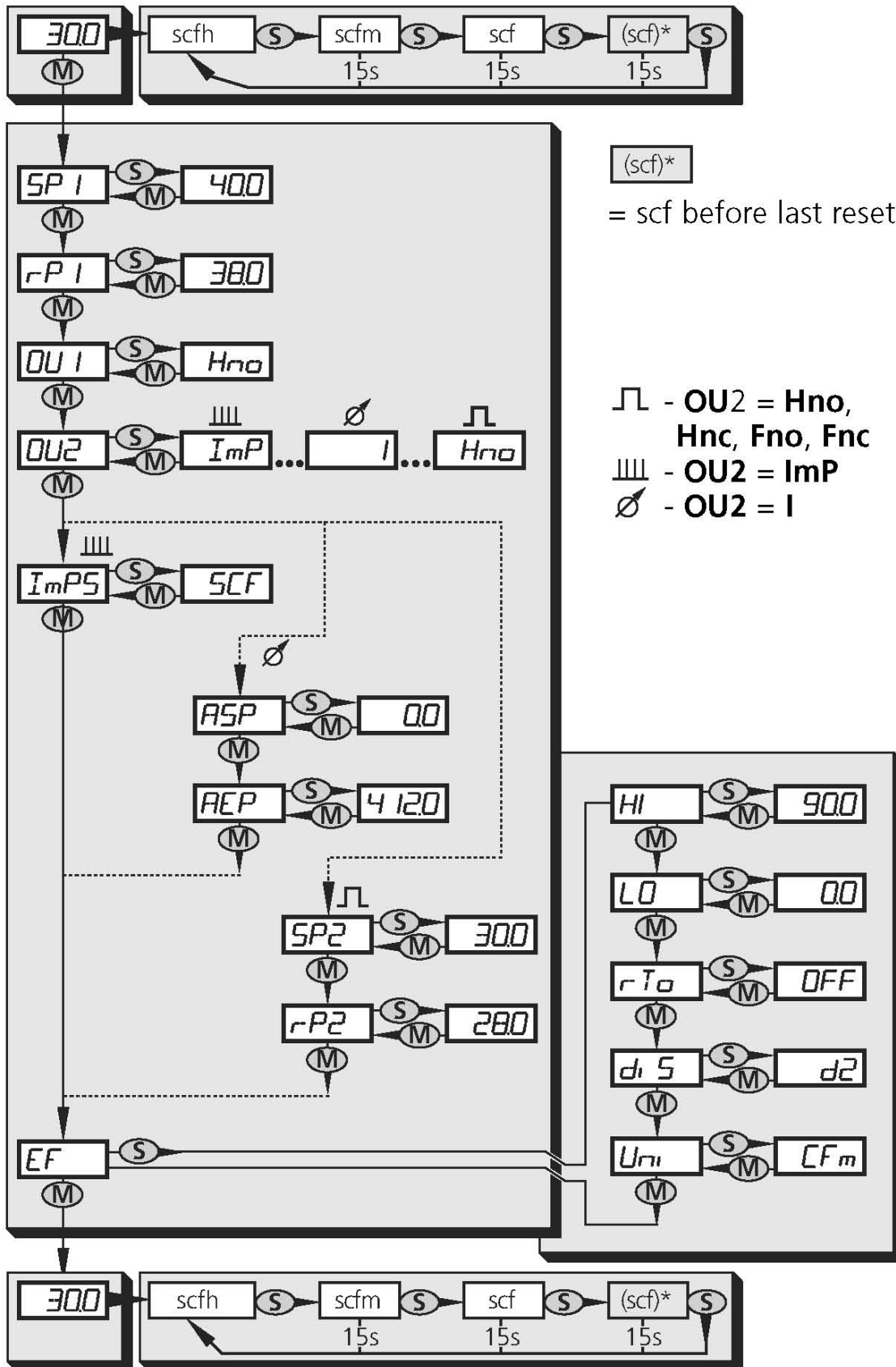

PROGRAMMING

Select the display unit (Uni) before setting the values for the parameters. This avoids rounding errors generated internally during the conversion of the units and enables exact setting of the values. The setting at the factory is Uni=CFH.

If no button is pressed for 15 seconds during the setting procedure, the unit returns to the Run Mode with unchanged values.

The unit can be electronically locked to prevent unwanted adjustment of the set parameters by pressing both push buttons until "LOC" is displayed. With the unit in the locked state "LOC" is indicated briefly when you try to change parameter values. To unlock press both push buttons until "ULO" is displayed. Units are delivered from the factory in the unlocked state.

OPERATING MODES

Run Mode:

Normal operating mode. Unit will perform its measurement and evaluation functions and provide output signals according to set parameters. Totalizer adds pulses of consumed quantity and displays them as current consumption value since last reset. Totalizer stores intermediate values every 10 minutes as well as elapsed time of set automatic reset. After a voltage dip this value is available as the current count of the totalizer (possible data loss can be maximum 10 minutes). Display indicates current measured values, yellow LED's signal switching status of outputs. Display unit can be temporarily changed (press "Set" button briefly, after 15 seconds unit returns to display unit set in menu point Uni).

Display Mode:

Indicates parameters and set parameter values. When "Mode/Enter" button is pushed briefly, unit passes to Display mode, which allows parameter values to be read. Unit's internal sensing, processing, and output functions continue as if in Run mode. Parameter names are scrolled with each press of "Mode/Enter" button. When "Set" button is pushed, corresponding parameter value is displayed for about 15 seconds. After another 15 seconds, unit returns to Run mode.

Programming Mode:

Setting parameter values: While viewing a parameter value pressing the "Set" button for more than 5 seconds causes unit to enter programming mode. Alter parameter by pressing "Set" button and confirm new value by pressing "Mode/Enter" button. Internal sensing, processing, and output functions continue as if in Run mode with original parameter values unless a new value is confirmed. Unit returns to Run mode when no button has been pressed for 15 seconds.

ADJUSTABLE PARAMETERS

<i>SP1</i> <i>SP2</i>	Switch-on point 1 / 2 Upper limit value at which the output changes its switching status. SP2 is only active if OU2 = Hno, Hnc, Fno or Fnc.		
	Switch-off point 1 / 2 Lower limit value at which the output changes its switching status. rPx is always lower than SPx. The unit only accepts values which are lower than SPx. Changing the switch-on point also changes the switch-off point (the distance between SPx and rPx remains constant). If the distance is higher than the new switch point, it is automatically reduced (rPx is set to the minimum setting value). rP2 is only active if OU2 = Hno, Hnc, Fno or Fnc. Setting ranges:		
	SP1 / SP2	rP1 / rP2	in steps of
	scfm 3.4 ... 412.0	1.40 ... 410.0	0.1
	10 ³ scfh 0.21 ... 24.72	0.08 ... 24.60	0.01
<i>OU1</i>	Configuration of output 1 4 switching functions can be set: • Hno = hysteresis function / normally open • Hnc = hysteresis function / normally closed • Fno = window function / normally open • Fnc = window function / normally closed		
<i>OU2</i>	Configuration of output 2 6 settings can be selected: - Output signals for flow rate: • Hno = hysteresis function / normally open • Hnc = hysteresis function / normally closed • Fno = window function / normally open • Fnc = window function / normally closed • I = analogue signal (4 ... 20mA) - Output signal for consumed quantity: • ImP = pulse (1 pulse/scf)		
<i>ASP</i>	Analogue start point Measured value at which 4mA is provided. ASP is only active if OU2 = I.		
<i>AEP</i>	Analogue end point Measured value at which 20mA is provided. Minimum distance between ASP and AEP = 25% of the final value of the measuring range. AEP is only active if OU2 = I. Setting ranges:		
	ASP	AEP	in steps of
	scfm 0.0 ... 309.0	103.0 ... 412.0	0.1
	10 ³ scfh 0.00 ... 18.54	6.18 ... 24.72	0.01
<i>ImPS</i>	Pulse setting • SCF = 1 pulse per scf (pulse length: 100ms). ImPS is only active if OU2 = ImP		
<i>EF</i>	Enhanced functions This menu item contains a submenu with additional parameters. You can access these parameters by pressing the SET pushbutton briefly.		
<i>HI</i> <i>LO</i>	Min-Max memory for flow rate • HI : displays the highest measured flow rate • LO : displays the lowest measured flow rate Erase the memory: - Press the "Mode/Enter" pushbutton until HI or LO is displayed. - Press the "Set" pushbutton and keep it pressed until "- - -" is displayed. - Then press the "Mode/Enter" pushbutton briefly. It is recommended to erase the memory as soon as the unit starts working under normal operating conditions.		

rTo	<p>Reset of the quantity meter After a defined period the meter is automatically erased and a new metering interval starts. The following periods can be set:</p> <ul style="list-style-type: none"> • 1h ... 23h (reset after 1 ... 23 hours), • 1d ... 6d (reset after 1 ... 6 days), • 1w ... 8w (reset after 1 ... 8 weeks). <p>In addition:</p> <ul style="list-style-type: none"> • OFF = reset after overflow of the meter (32-bit number overflow, i.e. overflow at 4,294,967.295 scf). • rES = manual reset: The meter is manually erased and a new metering interval starts: <ul style="list-style-type: none"> - Press the "Set" pushbutton until rES is indicated. - Then briefly press the "Mode/Enter" pushbutton. A manual reset can also be carried out if a period is set for automatic reset.
d, S	<p>Setting of the display 7 settings can be selected:</p> <ul style="list-style-type: none"> • d1 = update of the measured value every 50ms. • d2 = update of the measured value every 200ms. • d3 = update of the measured value every 600ms. <p>The update interval only refers to the display. It has no effect on the outputs.</p> <ul style="list-style-type: none"> • rd1, rd2, rd3 = display as for d1, d2, d3, but rotated by 180°. • OFF = In the Run mode the display of the measured value is deactivated. <p>If one of the pushbuttons is pressed, the current measured value is displayed for 15s. Another press of the Mode/Enter pushbutton opens the Display mode. The LEDs remain active even if the display is deactivated.</p>
Uru	<p>Display unit 3 settings can be selected:</p> <ul style="list-style-type: none"> • CFh = flow rate in 10³ standard cubic feet / minute • CFm = flow rate in standard cubic metre / hour • SCF = quantity meter in 10³ standard cubic feet <p>Select the display unit before setting the values for the parameters SPx, rPx, ASP and AEP. This avoids rounding errors generated internally during the conversion of the units and enables exact setting of the values.</p>

Chart 3

Hysteresis Function:

Keeps switching state of output stable if flow rate varies about preset value. With flow rate rising, output switches when switch-on point has been reached (SPx). With flow rate falling, output does not switch back until switch-off point (rPx) has been reached. To adjust hysteresis: set switch-on point, then set switch-off point at requested distance.

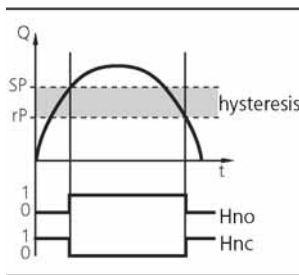

Figure 5

Window Function:

Enables monitoring of a defined acceptable range. When flow rate varies between switch-on point (SPx) and switch-off point (rPx), output is switched (window function/NO) or not switched (window function/NC). Width of window can be set by means of the difference between SPx and rPx. SPx=upper value, rPx=lower value.

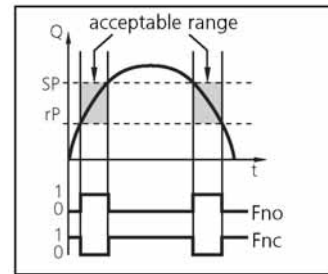

Figure 6

Scaling measuring range (analog output):

Analog start point (ASP) is the measured value at which the output signal 4 mA is defined. Analog end point (AEP) is the measured value at which the output signal 20 mA is defined. Minimum distance between ASP and AEP = 25% of final measuring range value. Output signal ranges from 4 to 20 mA in set measuring range. Output is also indicated by: flow rate above measuring range (output signal > 20 mA), or flow rate below measuring range (output signal between 3.6 and 4 mA).

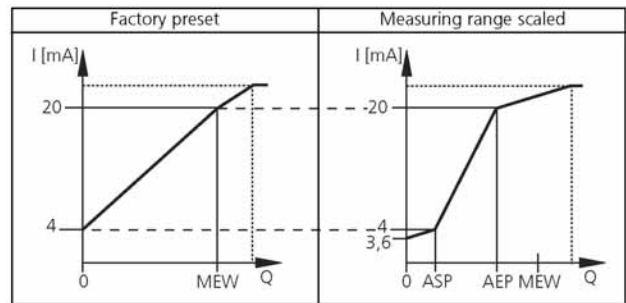

Figure 7

Fault Indication

OL: Detection range exceeded (flow rate > 120% of final value of measuring range)

- SC 1: Flashing - short circuit in switching output 1*
- SC 2: Flashing - short circuit in switching output 2*
- SC: Flashing - short circuit in both switching output*
- Err: Flashing - fault in measuring probe

*Concerned output is switched off as long as short circuit continues. Faults are indicated even if display is deactivated.